

ELEVATION RAMP INSTALLATION MANUAL

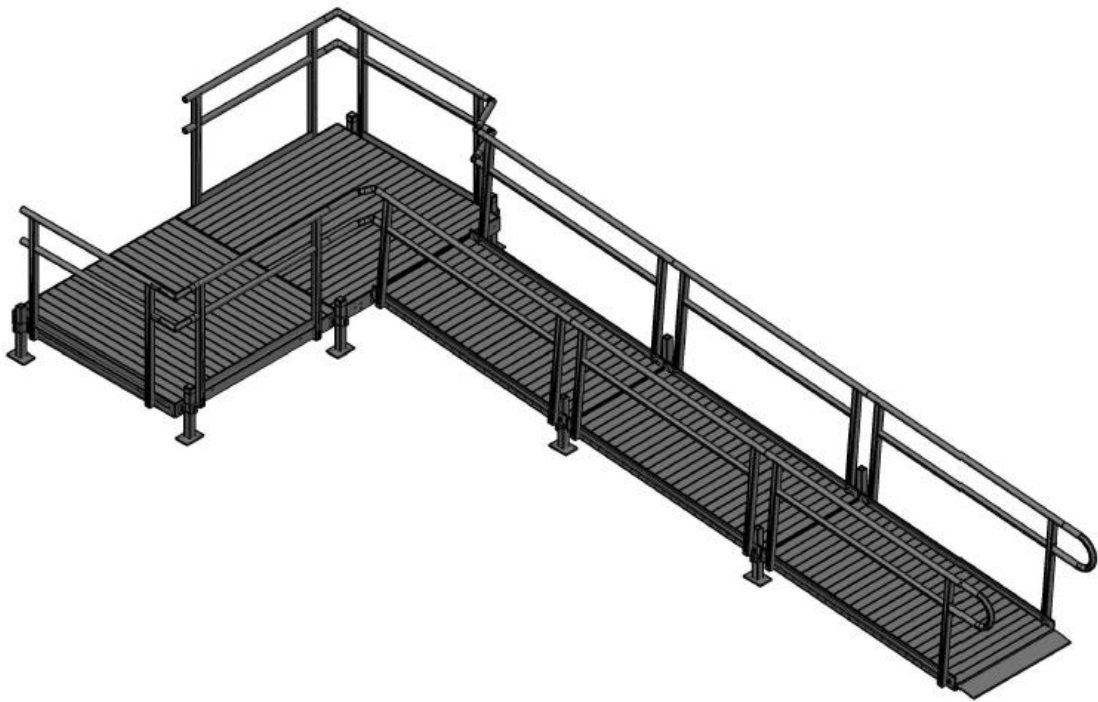

Safety Notice:

Personal Protective Equipment should be worn when handling or installing modular ramping. Installers should wear long pants with appropriate footwear that provides toe protection. Gloves should always be worn when handling the equipment. Eye and ear protection should be used whenever cutting or drilling metal.

Compliance Notice:

The dealer is responsible to verify and meet all applicable codes pertaining to this ramp installation. It is recommended that the dealer be familiar with the U.S. 2010 ADA Standards for Accessible Design.

Warranty Notice:

Harmar ramps are designed for residential use only. Each ramp section is rated to withstand 850 pounds. Installing this product in a non-residential application voids all warranties and the dealer is responsible for all damages/liabilities that may occur. Complete warranty details provided on the following page.

TABLE OF CONTENTS

Product Specifications	4
Before You Start	5
Installation Flowchart	6
Recommended Tools	7
Platform Assembly	8
Mounting The J-Hook	9
Ramp Run Assembly	10-11
Ramp Run Handrail Assembly	12
End Loop Handrail Assembly	13
Platform Handrail Assembly	14-15
Final Inspection	16

Warranty Information

Harmar, warrants to the “original purchaser” a three-year limited warranty for any Elevation Ramps modular ramping and its components that are deemed “warranted” by the original manufacturer. If modular ramp and its components are not deemed “warranted” the the original manufacturer then Hamrar will in turn not warranty any cost for service, repair or replacement with said parts.

Harmar only warraties to the “original purchaser” for said Elevation Ramps modular ramping and its components supplied by Harmar. This warranty is non-transferrable and in no event will Harmar be responsible for any direct or indirect damages to the modular ramp and its components. Harmar will not warrant damages to the Elevation Ramps modular ramping and its components due to the direct or indirect violation of the 850 lb weight limit or safety measurements stamped on said Elevation Ramps modular ramping and its components.

Harmar does not warrant any damage or failure of the modular ramp and its components caused by misuse, abuse, accidents, physical damage or modifications or replairs made by anyone other than Harmar Authorized Dealers or an Elevation Ramps authorized representative.

Product Specification Drawings

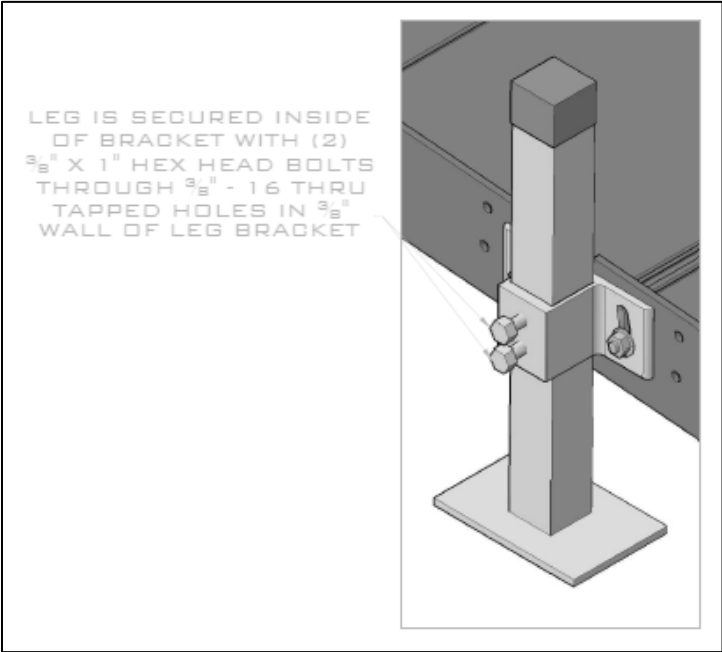
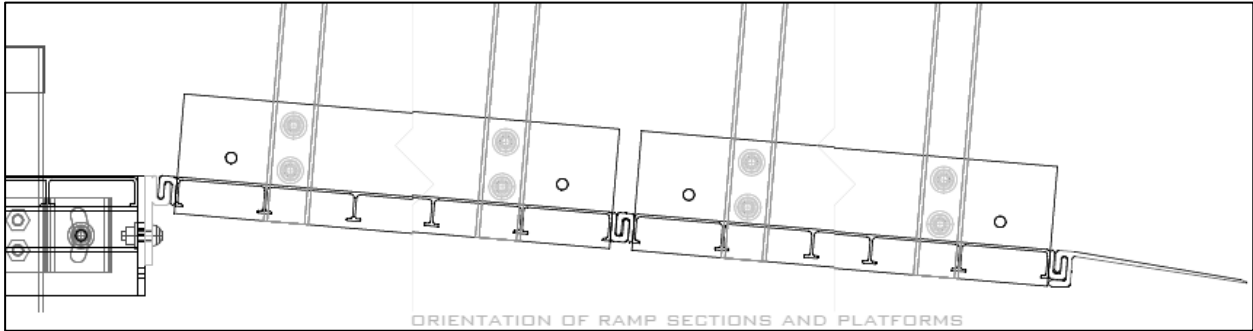
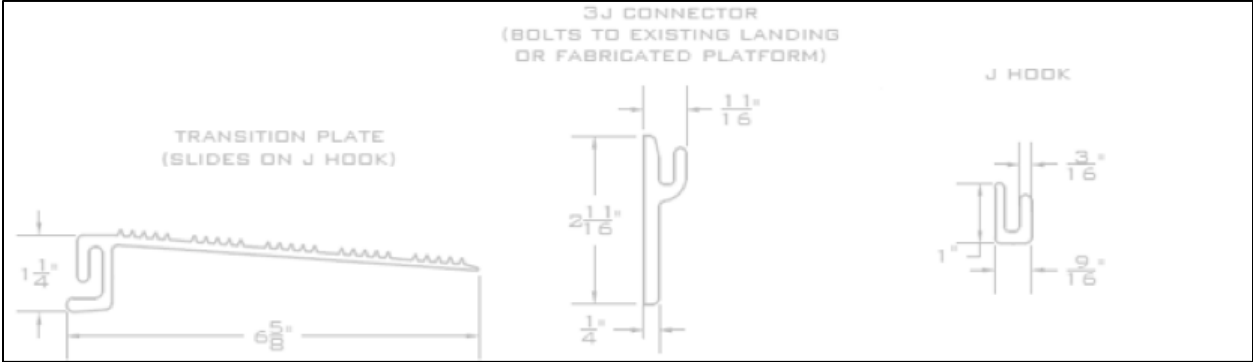

Before You Start

1. Review all relevant documentation.
 - a. Site photos
 - b. Field drawings
 - c. Assessment form
 - d. Harmar configuration drawing
 - e. Harmar components list
2. Verify all site work has been completed in advance.
3. Consider if paver stones or a landing pad will be needed.
4. Verify all parts/components are loaded.
5. Verify all tools are loaded.
6. Verify all post-installation documents are ready.
7. Consider the “what ifs”... Bring extras when in doubt.

Installation Flowchart

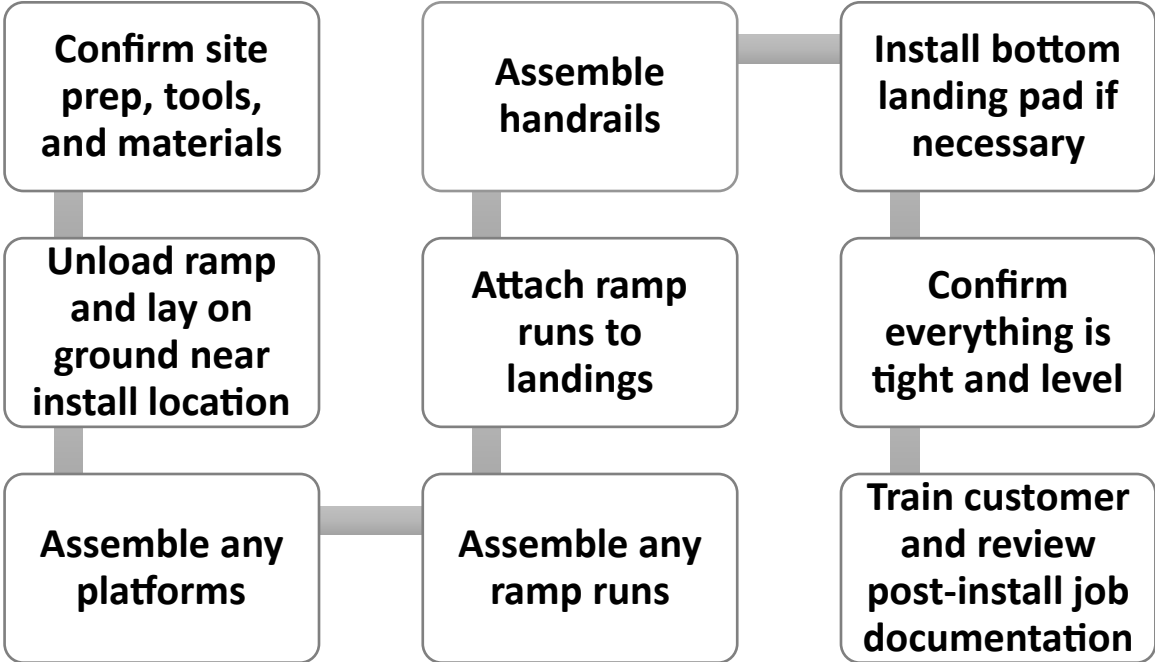

Recommended Tools & Supplies

- Impact wrench + drill (battery powered)
- Socket adapter for impact wrench
- Drill bits (metal, masonry, wood)
- #2 Phillips bit with driver guide
- 7/16", 1/2", 9/16" sockets w/ ratchet
- Tape measure
- 6" & 48" bubble level
- Metal cutting saw
- Metal file and deburring tool
- Hammer/Mallet
- 36" bar clamp
- Alignment tool (or screw driver)
- Lawn tools: shovel, rake, etc.
- PPE Safety Equipment



Tip: Driver Guides make drilling into pipe much easier and safer!



Tip: Bar clamps can pull or push an object to where you want it. Helpful with handrails!

Platform Assembly

1. Before attaching leg brackets to platform, determine the orientation of the platform. Consider size, the direction of the non-skid, and leg location.

2. Install leg brackets with legs to platform. Pull brackets up before tightening the two bolts with 1/2" nuts. Tighten one of two 9/16" bolts on each leg bracket with the leg slid down to the appropriate height.

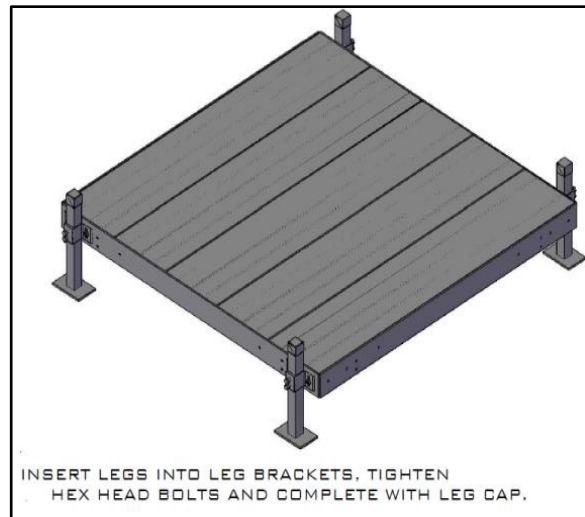

3. Confirm the height of the platform is appropriate and then level the platform using a 48" bubble level. Always level up so that you do not change the overall height of the platform. If platform is to be installed against an existing structure, consider leaving platform a bit out of level for water runoff.
4. Tighten all 9/16 bolts to lock the legs in place. The legs are held via pressure – there is no need to penetrate through the leg with the bolt. **It is normal for the bolt head to protrude out from the bracket.**
5. Verify all hardware is tight.

Mounting The J-Hook

1. Properly securing the J-Hook is **critical** for ensuring the safety of the ramp system. The J-Hook is responsible for supporting the top of the upper most ramp section. The J-Hook also ensures the ramp does not pull away from the landing.

2. If connecting a ramp run to a Harmar platform, the J-Hook should first be installed to the platform with provided bolt, washer, and 1/2" nut. The platform is predrilled in the middle of all sides for the J-Hook attachment.

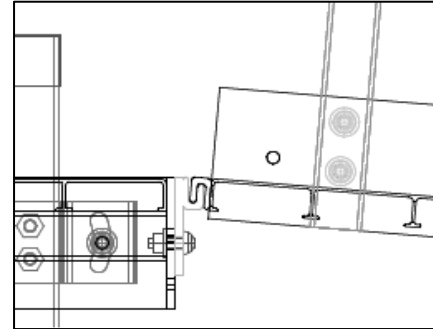

TIP: When installing J-Hook onto a turning platform, you can mount it off center to provide an increase in turning radius. This requires that you drill your own holes into the platform for the J-Hook attachment.

3. If your ramp run will be connecting to an existing structure, you must first mount the J-Hook to that structure. The top edge of the J-Hook should be level with the landing. The J-Hook must be plumb vertically once securely fastened.



4. You are responsible for determining the appropriate fastener for the material you are attaching to. Check local codes and hardware specifications. When working with brick or other unstable materials, it is recommended to add two leg brackets with legs to support the load. This does not replace the need for the J-Hook.

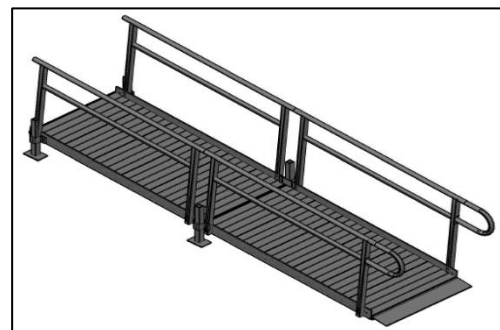

Ramp Run Assembly

1. Attach J-hook to the upper landing using the appropriate fasteners. The upper landing may be an existing structure or a Harmar platform.

2. **Installation Method 1:**

- a. Install first section of ramp into J-Hook and then attach leg brackets with legs. It is helpful to rest the bottom end of the ramp section on top of something while mounting the brackets/legs. Lift ramp section to appropriate height and tighten both brackets and both legs.



- b. Level ramp section from side to side and securely tighten fasteners. Leaving one side a bit loose will make sliding in the next ramp section much easier but you must go back and tighten.

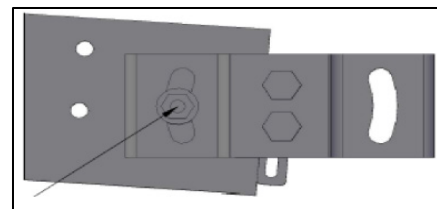

TIP: Load leg into bracket before attaching to ramp section.

- c. Confirm slope is consistent and of appropriate grade.

- d. Repeat steps A-C for each additional section of ramp. Before installing the last section of ramp, slide the transition plate into the bottom side groove. Avoid getting dirt or contaminants into connection.

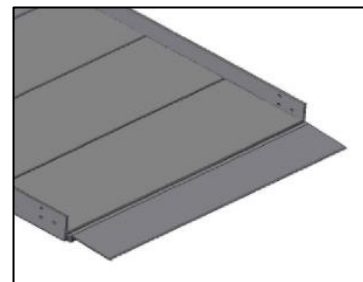

Ramp Run Assembly

1. Attach J-hook to the upper landing using the appropriate fasteners. The upper landing may be an existing structure or a Harmar platform.
2. **Installation Method #2:**
 - a. On flat ground, connect all ramp sections within a ramp run by way of the tongue and groove system.
 - b. Attach ramps together with two leg brackets at each joint. Installing legs at this point will create more drag when lifting the ramp and mounting to the J-Hook. They can be added once ramp is inclined and self-supporting.

-
-
- c. Install transition plate into bottom groove on the last section of the ramp run. Avoid getting dirt or contaminants into connection.

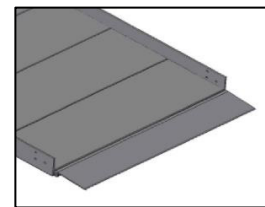

-
-
-
- d. Carefully lift the top of the ramp run and slide the entire run into the previously installed J-Hook. **This should only be attempted with two technicians and an acceptable length of ramp.**

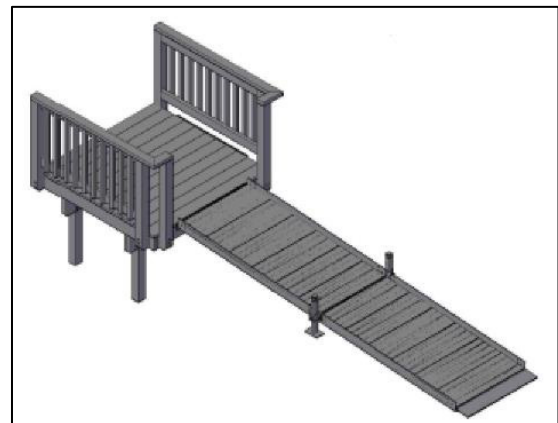

TIP: The less friction, the lighter this will feel. Try sliding a furniture dolly under the bottom of the ramp to reduce friction as you lift and slide into position.

Ramp Run Handrail Assembly

1. Secure handrails to ramp section with the 2" carriage bolt, washer, and 1/2" nut. When possible, install rails with ramp lying flat on the ground, but this can also be done on an incline. If bolt holes do not line up, use an alignment tool or bar clamp to assist. It may be necessary to temporarily lower a leg, secure the rails, and reset the leg.



2. Before attaching the next section of rail, you must install the connection sleeve into the upper tube on the handrail. Slide connection sleeve roughly half way into upper tube and secure with provided self-tapping screw. The handrail tubing is already predrilled for this connection. Using a driver guide while installing the #2 screws is highly recommended for speed and safety.

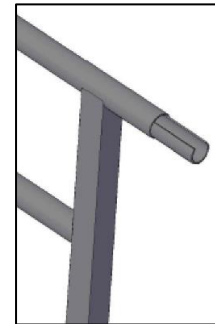

3. With connection sleeve installed, you can now mount the second handrail. Slide second handrail into connection sleeve and then rotate down and align with bolt holes.

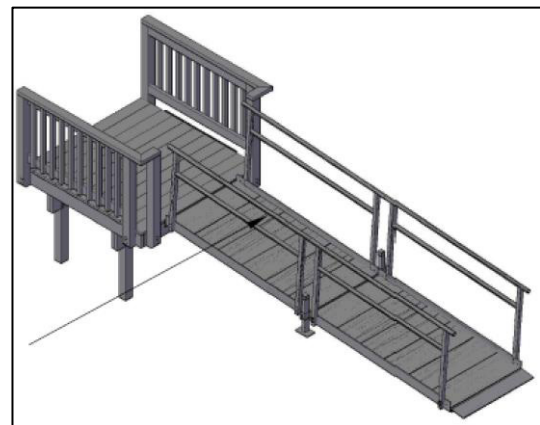

4. Install second self-tapping screw into the opposite side of each connection sleeve. Use predrilled hole in upper tube of handrail. Each rail joint should have one connection sleeve and two screws.

End Loop Handrail Assembly

1. With handrails completed along both sides of the ramp run, you can now install any end loops specified by your application drawing.

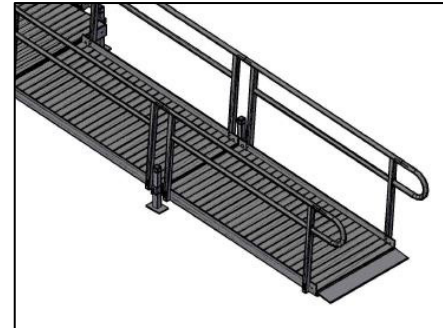

2. Begin end loop installation by installing connection sleeves into end loop. Use predrilled holes and provided self-tapping screws.

3. With connection sleeves secured to end loop, install handrail starter bracket on the lower tube of the end loop. Use predrilled holes to determine orientation. The predrilled holes will face down to the ground once installed to the ramp handrail.

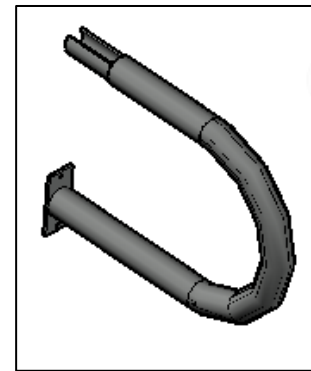

4. Finish installation by sliding the exposed connection sleeve into ramp handrail. While holding the joint tight, install provided self-tapping screw through predrilled hole in the upper rail. With the upper connection completed, secure handrail starter bracket into handrail with 2 self-tapping screws. Install remaining screws to complete the connection.

Installing handrail starter bracket to handrail before making the upper connection will typically result in an unsatisfactory joint between end loop and handrail.

Platform Handrail Assembly

1. Per application drawing, install standard rails and secure with provided 2" bolts, washers, and 1/2" nut. When installing platform handrails, ensure the flat side of the wheel guard is facing in towards the ramp surface.

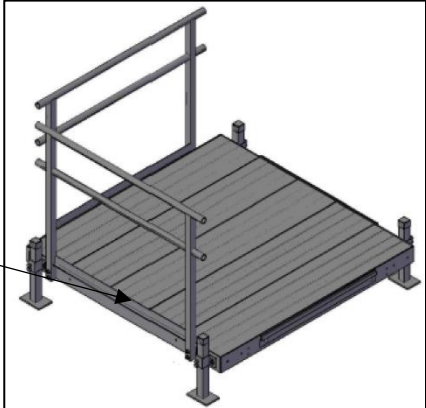

Turning platforms will appear as illustrated while a straight platform will have rails on the opposite sides of each other.

2. If installing a turning platform, you must assemble the 90-degree closure kit **before** mounting both rails. Assemble closure kit as shown and secure with provided self-tappers. Install assembled closure kit into handrail previously secured to platform. Aligning both the upper and lower tubes, slide the remaining handrail onto the closure kit. Secure handrail with provided 2" bolts, washers, and 1/2" nut. Secure closure kit to both handrails with provided self-tapping screws.

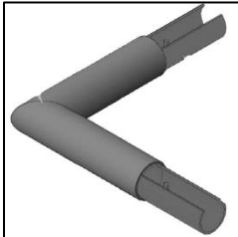
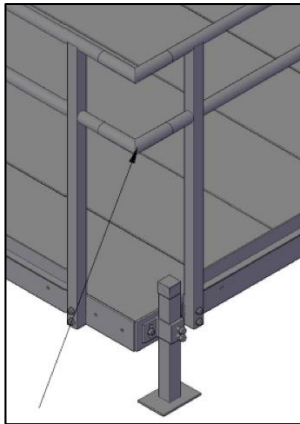

The connection between platform handrail and ramp handrail will require measuring and cutting on site.

Platform Handrail Assembly

1. Before connecting the platform handrails to ramp handrails, you will first need to assemble the adjustable elbows.

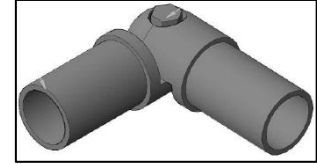

2. Slide assembled elbow into upper platform handrail and secure with self-tapping screw. Repeat process for lower handrail as well.

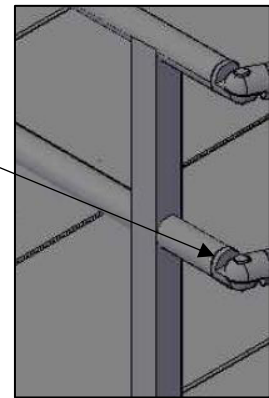

3. Slide another elbow (#3) into upper ramp handrail but do not secure with screw yet. For lower handrail, you will first need to install a handrail starter bracket before sliding in the adjustable elbow (#4). The height of the handrail starter bracket should be matched to that of the other lower rails.

4. With adjustable elbows in place, installer must measure and cut provided tubing to fit tightly between the rails. **Avoid leaning on either rail when measuring the tubing.** To scribe a line, slide provided piece of tubing onto the upper elbow on the platform handrail. Position towards upper elbow on ramp handrail. Mark the tubing where it will need to be cut to fit properly. Repeat process for lower handrail.

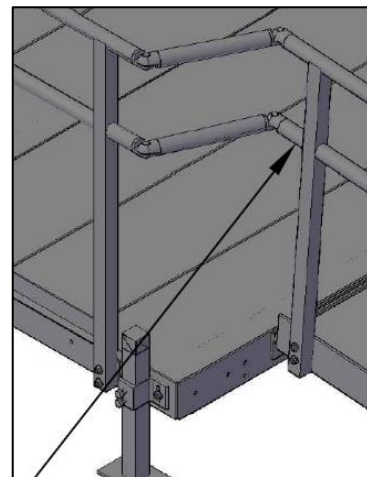

5. Cut tubing to length. The inside and outside of the tubing will need to be deburred before installation.
6. Install cut-to-size tubing onto both upper adjustable elbows. Secure with 4 self-tapping screws. Repeat process for lower tube as well.

Final Inspection

Before the customer uses the ramp, it is critical that the installer(s) perform a final inspection of the ramp system.

- ❑ Attachment to home is solid and adequately fastened.
- ❑ All hardware is installed and tightened appropriately. It is recommended to walk the length of the ramp (both sides) and snug all bolts with a ratchet/socket combo.
- ❑ All legs are properly supported and that the lower transition plate sits flush with the terrain.
- ❑ All ramp sections are leveled and pitched to the appropriate slope. From the bottom looking up, you can view the pitch of the ramp by sighting the upper handrail with your eyes.
- ❑ All handrail joints are smooth and there are no sharp edges. It may be necessary to file down any rough spots. Run your hands along the full length of the handrail on both sides of the ramp.
- ❑ Railings have end caps installed where applicable and all ramp legs are capped.
- ❑ Job site is cleaned and there are no metal or metal shavings left on the customers property.